

D *Ersatzteilliste* **Motor-Druckspritze** **432**

Inhaltsverzeichnis

Seite
2 Motor
3 Luffilter, Vergaser, Auspuff
4 Zündung und Gaszug
5 Benzintank
6 Lüfterdeckel
7 Tragegestell
8 Behälter, Tragegurt
9 Spritzrohr
10 Ventil
11 Pumpe
12 Ersatzteile
12 Bestell-Richtlinien

GB *Spare parts list* **Motor-Sprayer** **432**

Table of contents

Page
2 Engine
3 Air filter, carburetor, exhaust
4 Ignition and Throttle Cable
5 Fuel tank
6 Cover
7 Carrying frame
8 Tank, Carrying strap
9 Spray wand
10 Valve
11 Pump
12 Spare Parts
12 Directions for Ordering

F *Liste de pièces de rechange* **Pulvérisateur à moteur** **432**

Table des matières

Page
2 Moteur
3 Filtre à air, carburateur, échappement
4 Allumage et câble accélérateur
5 Réservoir à essence
6 Capuchon de ventilateur
7 Cadre porteur
8 Réservoir
9 Tube de pulvérisation
10 Soupape
11 Pompe
12 Pièces de rechange
12 Directives pour les commandes

E *Lista de piezas de recambio* **Pulverizador motorizada** **432**

Indice

Página
2 Motor
3 Filtro de aire, carburador, escape
4 Encendido y cable bowden
5 Deposito
6 Cubierta
7 Deposito
8 Deposito
9 Tubo
10 Valvula
11 Bomba
12 Piezas de recambio
12 Directivas de pedido

Motor- Druckspritze 432

solo®



Bild-Nr. Pos.-No. Pos.-No.	Bestell-Nr. Order-No. No. de Cde. Ref.-Nr.	Modell Type Modelo Modelo	Menge Quantity Nombres Cantidad	Motor	Engine	Moteur	Motor
1	20 00 628		1	SOLO 2-Takt-Motor 25 cm ³	Engine	Moteur 2-temps 25 cm ³	Motor
2	20 11 819		1	Nikasilzylinder Ø 33,00 mm	Cylinder	Cylindre	Cilindro
3	20 48 377		1	Kolbenring	Piston ring	Segment de piston	Anillo de piston
4	00 55 278		2	Sicherungsring 9x0,8 mm	Circlip	Arrêt axe de piston	Anillo de seguridad
5	20 31 90 225		1	Kolbenbolzen 9/6x26 mm	Piston pin	Axe de piston	Perno de embolo
6	22 00 490		1	Kolben Ø 33,00 mm	Piston	Piston	Piston
7	00 20 102		1	Sechskantmutter M6	Hex. nut	Ecrou	Tuerca
8	30 38 206		1	Ritzel 15x15 Antrieb	Drive sprocket	Pignon	Pinon
9	00 54 276		1	Wellendichring 12x32x7 mm	Oil seal	Joint d'arbre	Reten
10	00 54 258		2	Wellendichring 12x22x5mm	Oil seal	Joint d'arbre	Reten
11	21 00 12 125		2	Hülse Lager 12x34,17x15,5 mm enth. (-> 11, 12)	Sleeve incl. (-> 11, 12)	Douille y inclus: (-> 11, 12)	Casquillo incl. (-> 11, 12)
12	00 62 335		2	O-Ring 27x3 mm <-)	O-ring <-)	Joint torique <-)	Anillo<-)
13	00 31 258		2	Scheibe 12x18x1,8 mm	Washer	Rondelle	Arandela
14	22 00 133		1	Kurbelwelle enth. (-> 14, 15)	Crankshaft incl: (-> 14, 15)	Vilebrequin y inclus: (-> 14, 15)	Cigüenal incl. (-> 14, 15)
15	00 52 141		1	Nadelhülse 9x13x12 mm <-)	Needle sleeve <-)	Douille <-)	Casquillo <-)
16	00 75 100		1	Scheibenfeder 2x3,7 mm	Spring	Clavette	Resorte
18	24 00 125		1	Lüfterrad	Fan wheel	Turbine	Turbina
19	00 72 176		1	Scheibe 8,2x20x1 mm	Washer	Rondelle	Arandela
20	00 20 206		1	Sechskantmutter M8x1 mm	Hex. nut	Ecrou	Tuerca
22	20 63 372		2	Dichtungsteil Kurbelgehäuse	Sealing	Joint carter moteur	Junta
23	21 00 122		1	Kurbelgehäuse	Crankcase	Carter moteur	Carter cigüenal
24	00 72 140		4	Scheibe 5,2x12x0,5 mm	Washer	Rondelle	Arandela
25	00 18 399		4	Zylinderschraube M5x35 mm	F.H. screw	Vis	tornillo
27	00 18 326		1	Zylinderschraube M4x16mm	F.H. screw	Vis	Tornillo
28	20 74 562		1	Isoliererelement	Insulating element	Élément d'isolation	Elemento aislante
30	40 73 127		1	Abdeckhaube	Cover	Capot	Cubierta
31	00 18 274		2	Linsenschraube 5x16 mm	Screw	Vis	Tornillo
32	00 18 370		4	Linsenschraube 6x20 mm	Screw	Vis	Tornillo

Motor- Druckspritze 432

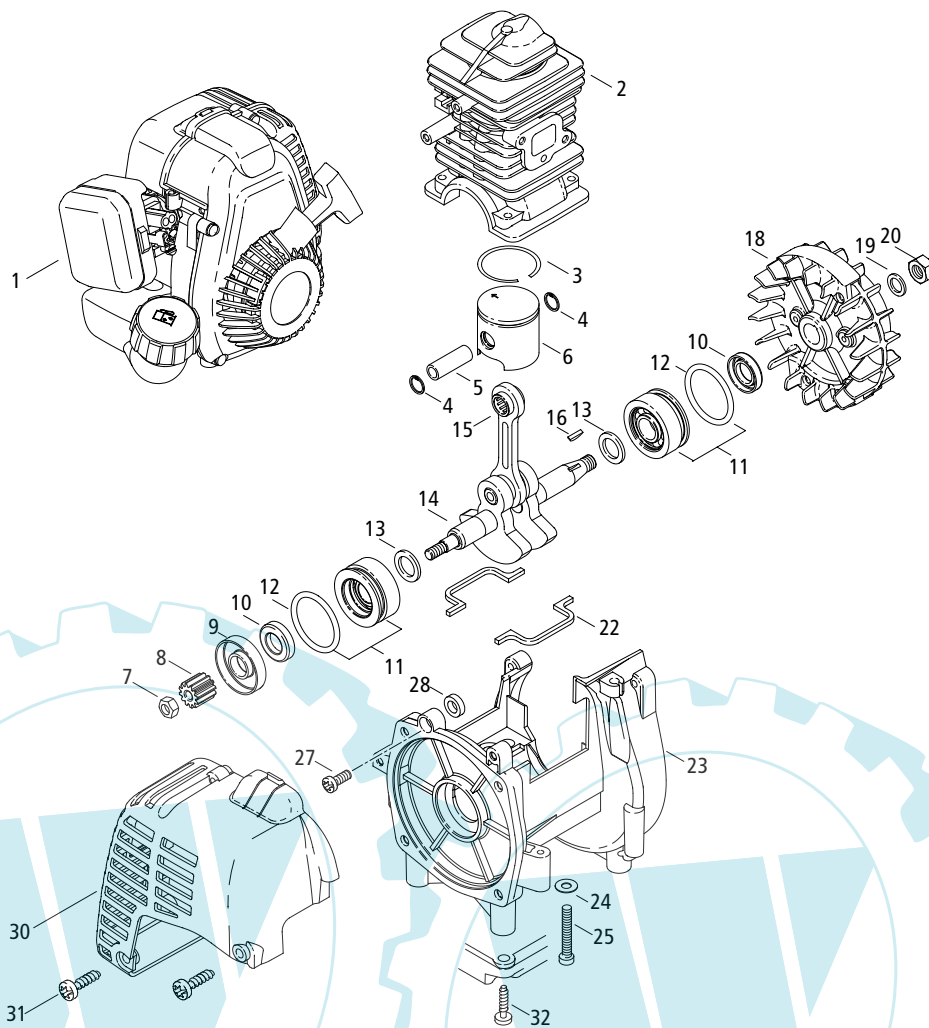

Bild-Nr. Pos.-No. Pos.-No.	Bestell-Nr. Order-No. No. de Cde. Ref.-Nr.	Modell Type Modélo Modelo	Menge Quantity Nombres Cantidad	Luftfilter, Vergaser, Auspuff	Air filter, carburetor, exhaust	Filtre à air, carbureteur, échappement	Filtro de aire, carburador, escape
1	20 11 819		1	Nikasilzylinder Ø 33,00 mm	Cylinder	Cylindre	Cilindro
2	20 61 518		1	Vergaserstutzendichtung	Manifold gasket	Joint de bride	Junta de brida
3	20 74 111		1	Ansaugstutzen	Socket	Bride d'aspiration	Brida
4	00 18 337		2	Zylinderschraube M5x20	F.H. screw	Vis	Tornillo
5	20 61 464		1	Vergaserdichtung	Carburetor gasket	Joint de carburateur	Junta carburador
6	23 00 825		1	Vergaser mit Primer	Carburetor w.primer	Carburateur	Carburador
7	05 10 985		1	Dichtsatz-Vergaser	Gasket kit	Jeu de joints	Juego de juntas
8	05 10 984		1	Reparaturatz-Vergaser	Repair kit	Jeu de réparation	Juego rep.
9	20 74 905		1	Haltering	Ring	Bague de retient	Anillo
10	25 00 810		1	Luftfilter enth. (-> 10, 11	Air filter incl. (-> 10, 11	Filtre à air y inclus (-> 10, 11	Filtro de aire incl. (-> 10, 11
11	12 588		1	Filter <-)	Filter <-)	Filtre <-)	Filtro <-)
12	00 72 144		2	Sicherungsscheibe	Washer	Rondelle	Arandela
13	00 18 428		2	Linsenschraube 5x55 mm	Screw	Vis	Tornillo
18	00 18 365		2	Vierkantschraube M5x40 mm	Square nut	Ecrou	Tuerca
19	20 61 197		1	Auspuffdichtung	Exhaust gasket	Joint d'échappement	Junta escape
20	25 00 104		1	Auspuff (-> 20 - 23	Exhaust (-> 20 - 23	Echappement (-> 20 - 23	Escape (-> 20 - 23
21	00 13 229		2	Linsenschraube 5x55	Screw	Vis	Tornillo
22	25 00 651		1	Austrittsblech	Plate	Tôle de sortie	Chapa
23	20 61 142		1	Dichtung <-)	Gasket <-)	Joint <-)	Junta <-)
25	00 72 144		2	Sicherungsscheibe	Safety washer	Rondelle de sécurité	Arandela seguridad
26	00 72 140		2	Scheibe 5,2x12x0,5 mm	Washer	Rondelle	Arandela
27	00 28 137		2	Sechskantmutter M5	Hex. nut	Ecrou	Tuerca

Motor- Druckspritze 432

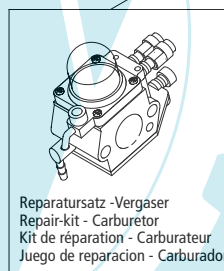
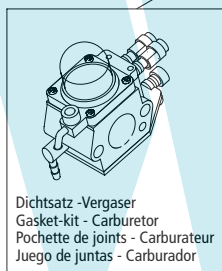
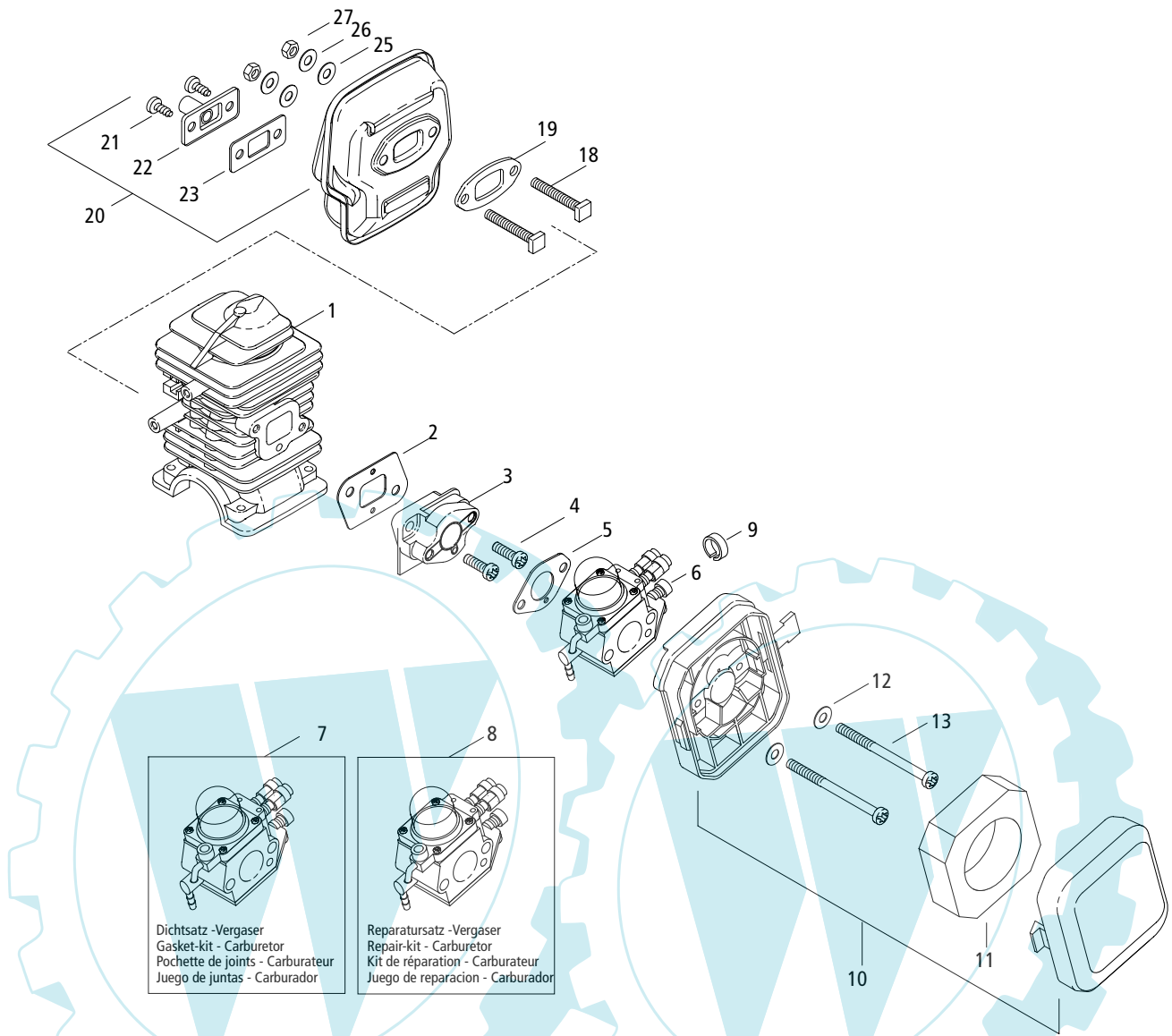

Bild-Nr. Pos.-No. Pos.-No.	Bestell-Nr. Order-No. No. de Cde. Ref.-Nr.	Modell Type Modélo Modelo	Menge Quantity Nombres Cantidad	Zündung und Gaszug	Ignition and Throttle Cable	Allumage et câble accélérateur	Encendido y cable bowden
1	00 15 299		2	Stiftschraube M4x35 mm	Stud screw	Goujon	Tornillo
2	00 33 401		2	Hülse 8x4,4x16 mm	Sleeve	Douille	Casquillo
4	00 72 148		2	Sicherungsscheibe	Safety washer	Rondelle	Arandela
5	00 30 135		1	Scheibe 4,3 125	Washer	Rondelle	Arandela
6	00 28 118		2	Sechskantmutter M4	Hex. nut	Ecrou	Tuerca
8	00 64 41 527		380 mm	Schlauch 8,5	Hose	Tuyau	Tube
9	28 00 575		1	Bowdenzug Gas	Throttle cable	Câble des gaz	Cable bowden
10	00 66 455		1	Kabelband 98x2,5mm, Natur	Cable band	Frein de câble	Cinta
12	00 84 869		1	Kabel Masse/Kurzschluss.	Ground cable	Câble de masse	Cable de masa
14	20 74 905		1	Haltering	Ring	Bague de retient	Anillo
19	00 18 282		1	Linsenschraube 5x45 mm	Screw	Vis	Tornillo
20	00 72 144		1	Sicherungsscheibe	Safety washer	Rondelle de sécurité	Arandela
21	40 73 624		1	Deckel	Cover	Couvercle	Tapa
22	40 73 623		1	Gashebel	Throttle lever	Accélérateur	Palanca gas
23	00 72 165		1	Scheibe 31,5x16,3x0,8 mm	Washer	Rondelle	Arandela
24	00 84 477		1	Schalter Kurzschluss	Short-circuit switch	Interrupteur	Interruptor
25	40 74 800		1	Gehäuse Motorsteuerung	Housing	Carter commande moteur	Carter
26	00 20 106		1	Sechskantmutter M4	Hex. nut	Ecrou	Tuerca
27	00 10 596		1	Zylinderschraube M4x45mm	F.H. screw	Vis	Tornillo
30	23 00 481		1	Zündmodul enth. (-> 30-32	Ignition coil incl. (-> 30-32	Volant électronique inclus: (-> 30-32	Bobina incl. (-> 30-32
31	00 73 360		1	Kontaktfeder	Contact spring	Ressort de contact	Resorte
32	00 84 621		1	Zündkerzenstecker <-)	Spark plug cover <-)	Capuchon de bougie <-)	Tapa de bujia <-)
33	23 00 730		1	Zündkerze WSR6F 200	Spark plug	Bougie	Bujia

Motor- Druckspritze 432

solo®

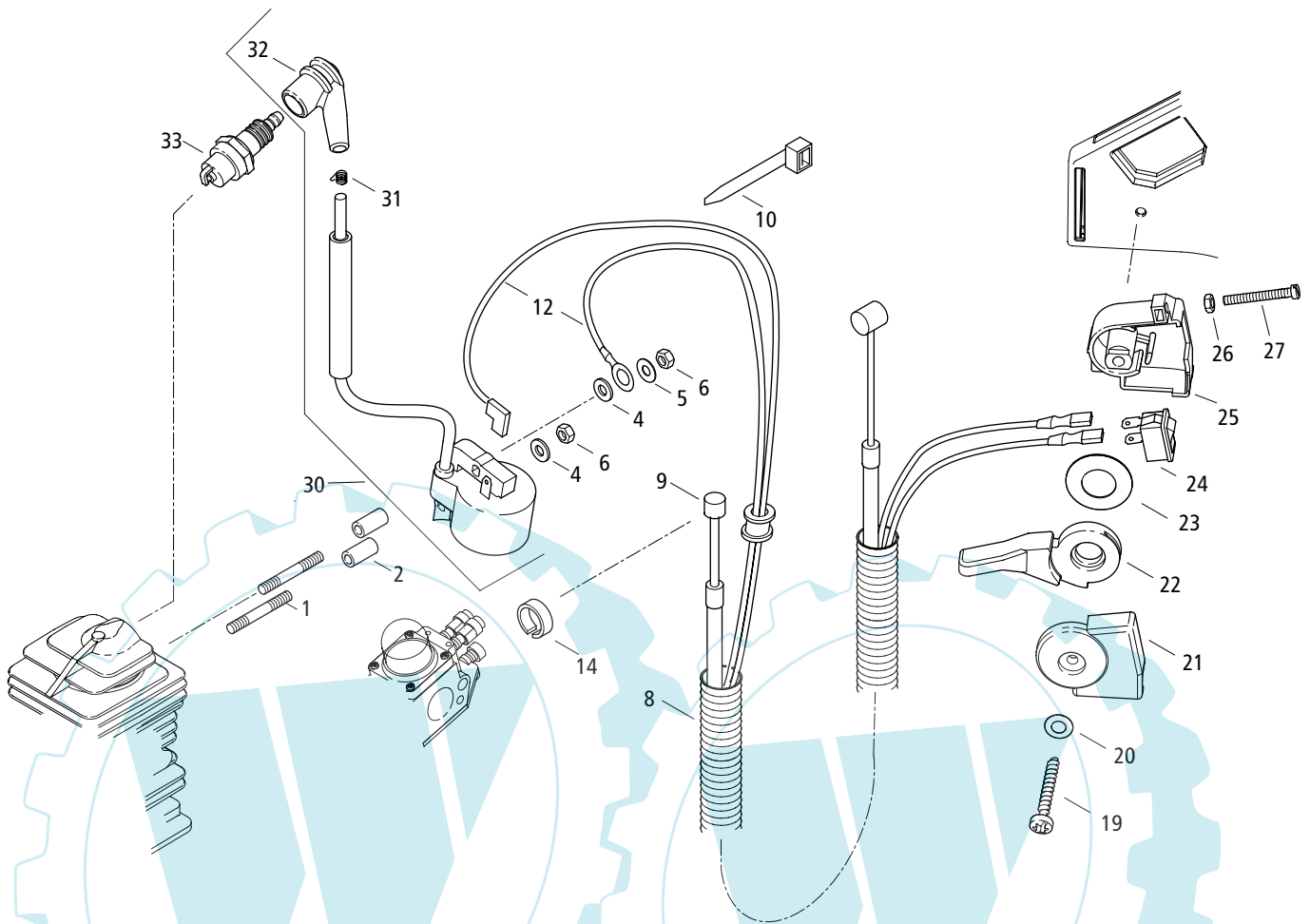

Bild-Nr. Pos.-No. Pos.-No.	Bestell-Nr. Order-No. No. de Cde. Ref.-Nr.	Modell Type Modélo	Menge Quantity Nombres Cantidad	Benzintank	Fuel tank	Réservoir à essence	Deposito
1	27 00 104		1	Benzintank enth. (-> 1-11	Fuel tank incl. (-> 1-11	Réservoir à essence y inclus: (-> 1-11	Deposito incl. (-> 1-11
2	27 00 187		1	Tankverschluss enth. (-> 2, 3	Tank lid incl. (-> 2, 3	Bouchon de réservoir inclus: (-> 2, 3	Cierre de deposito incl. (-> 2, 3
3	00 61 330		1	Dichtung 30,5x40,8x2 mm <-)	Gasket <-)	Joint <-)	Junta <-)
4	00 64 419		1	Schlauch 3x1,5x85mm Primerrücklauf	Hose	Tuyau	Tubo
5	40 63 253		1	Schlauch 3x103 mm Kraftstoff	Fuel hose	Tuyau	Tubo
6	27 00 416		1	Filter Benzinsucher	Fuel pick-up	Crépine d'essence	Filtro
7	00 64 419		1	Schlauch 3x1,5x85 mm Entlüftung	Ventilation hose	Tuyau d'aération	Tubo
8	27 00 405		1	Entlüftungsstutzen	Ventilation socket	Manchon d'aération	Munon
10	00 44 285		4	Rohrnieten 8x0,75x7 mm	Rivet	Rivet	Remache
11	00 94 197		4	Dämpfungsgummi <-)	AV element <-)	Amortisseur <-)	Elemento AV <-)
12	00 30 102		4	Scheibe 5,3 mm	Washer	Rondelle	Arandela
13	00 18 363		4	Linsenschraube 5x20 mm	Screw	Vis	Tornillo

Motor- Druckspritze 432

solo[®]

Bild-Nr. Pos.-No. Pos.-No.	Bestell-Nr. Order-No. No. de Cde. Ref.-Nr.	Modell Type Modélo Modelo	Menge Quantity Nombres Cantidad	Lüfterdeckel	Cover	Capuchon de ventilateur	Cubierta
1	40 73 129	bis 2003	1	Lüfterdeckel inkl. Startergehäuse	Fan cover incl. starter housing	Capuchon y inclus carter lanceur	Cubierta y caja de arranque
2	40 73 131	ab 2003	1	Lüfterdeckel ohne Starter	Fan cover w/o starter	Capuchon sans carter lanceur	Cubierta sin arranque
3	40 73 128		1	Zündkerzenabdeckung	Spark plug cover	Capuchon de bougie	Tapa de bujia
4	00 18 363		6	Linsenschraube 5x20 mm	Screw	Vis	Tornillo
5	00 18 354		4	Linsenschraube 4x12 mm	Screw	Vis	Tornillo
6	26 00 140		1	Starter-Universal enthält (-> 6-19)	Starter incl. (-> 6-19)	Lanceur y inclus: (-> 6-19)	Arranque incl. (-> 6-19)
7	21 00 126		1	Startergehäuse	Starter housing	Carter lanceur	Caja de arranque
8	26 00 284		1	Federkassette	Spring cassette	Cassette de ressort	Cassette
9	20 74 915		1	Seilrolle	Rope pulley	Poulie de câble	Roldana
10	20 74 343		1	Starterklinke	Pawl	Cliquet de lanceur	Trinquete
11	00 34 126		1	Federscheibe	Washer	Rondelle de ressort	Arandela
12	00 31 611		1	Scheibe 4,3x15x1mm	Washer	Rondelle	Arandela
13	20 74 977		1	Kulisse rot	Template	Coulisse	Colisa
14	20 31 965		1	Distanzstück 4,3x12,5x5 mm	Spacer	Pièce d'écartement	Espaciador
15	00 34 152		1	Sicherungsscheibe	Safety washer	Rondelle de sécurité	Arandela
16	00 73 365		1	Federstecker	Pin	Goupille beta	Clavija
17	00 10 519		1	Zylinderblechschraube. 3,5x22 mm	Screw	Vis	Tornillo
18	00 63 19 525		1	Starterseil 3x1050 mm	Starter rope	Câble lanceur	Cuerda de arranque
19	20 74 570		1	Startergriff <-)	Starter grip <-)	Poignée lanceur <-)	Empunadura <-)
20	00 69 890		1	Sks. Solo	Decal	Autocollant Solo	Adhesivo

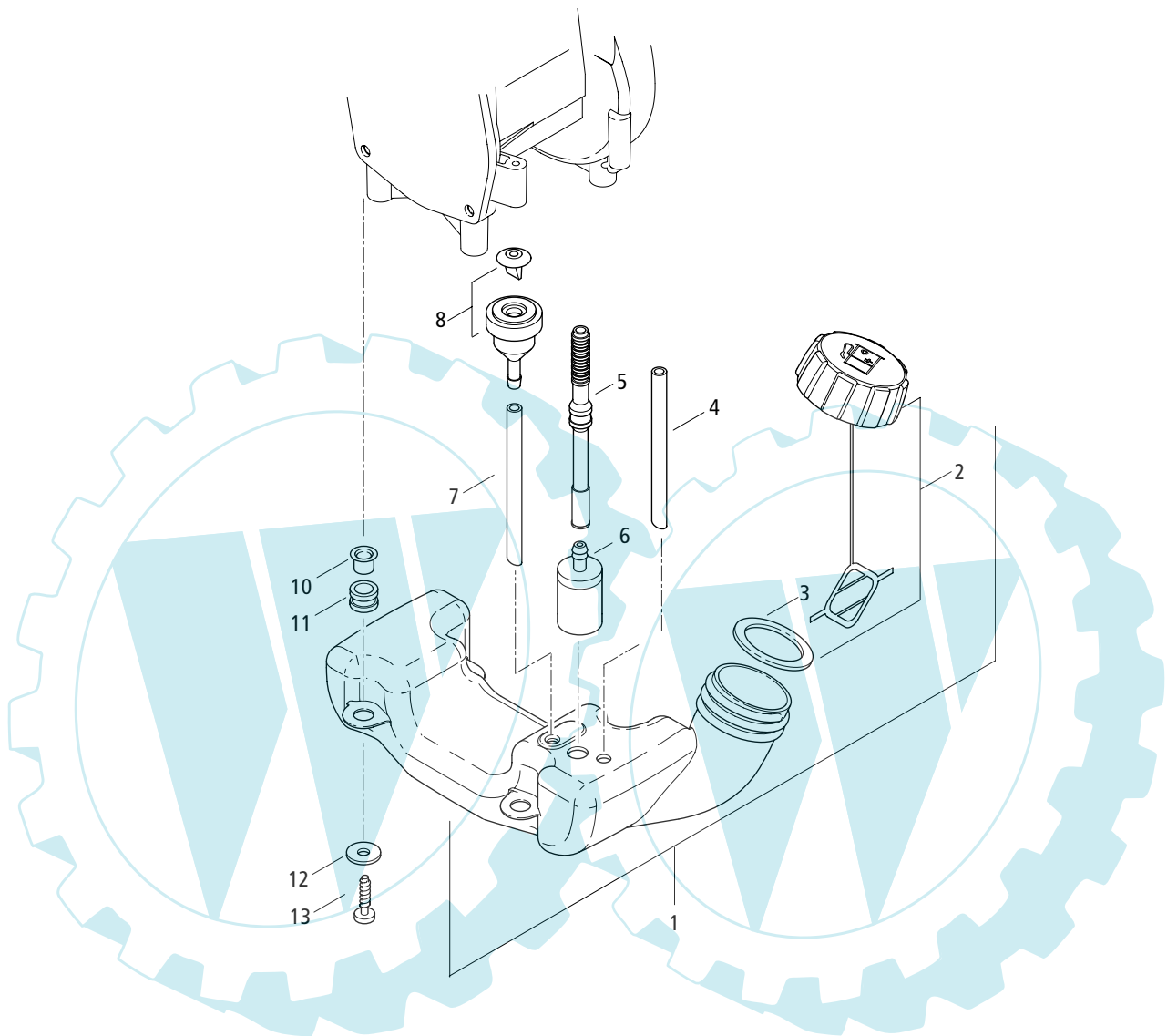
Motor- Druckspritze 432

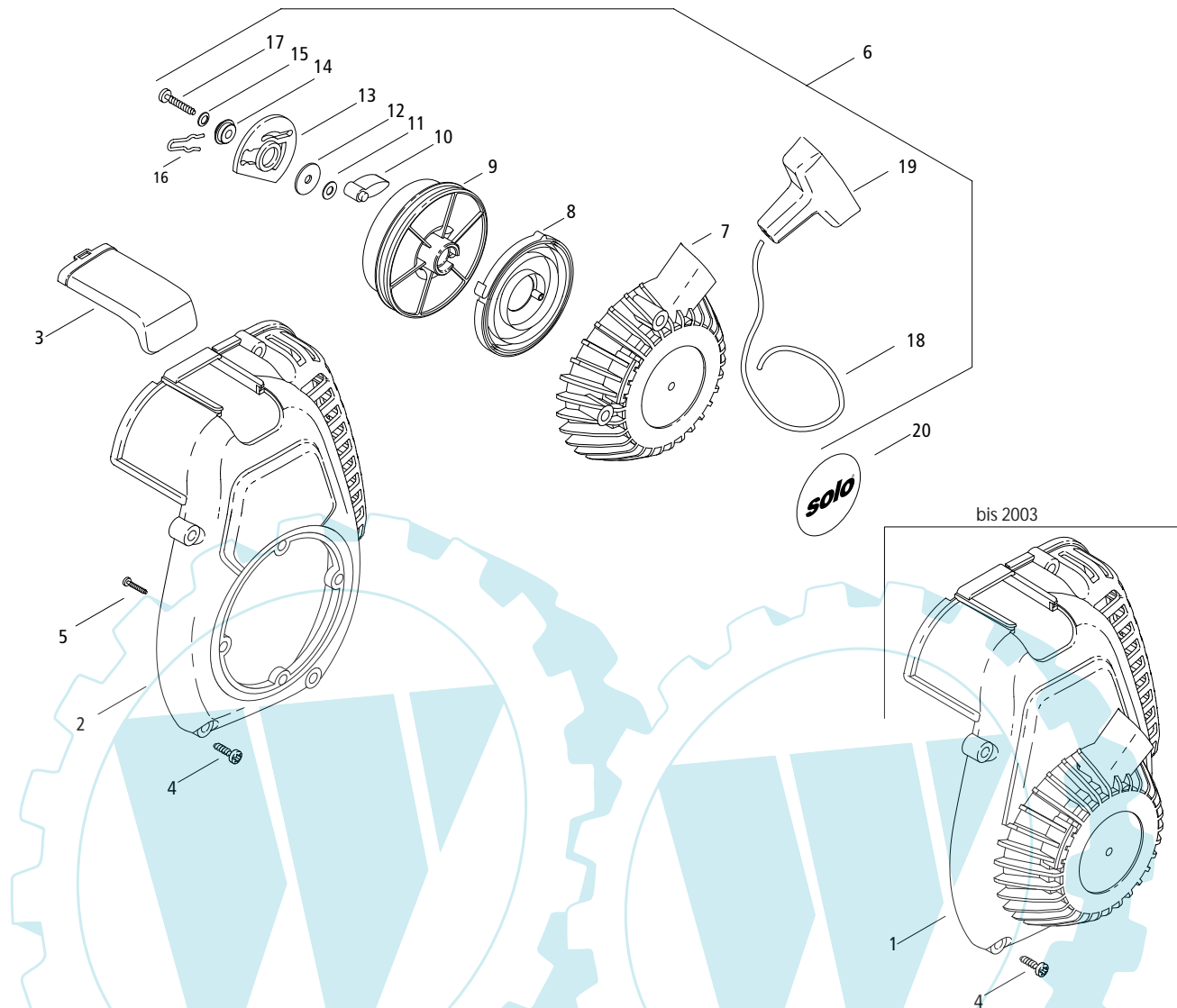

Bild-Nr. Pos.-No. Pos.-No.	Bestell-Nr. Order-No. No. de Cde. Ref.-Nr.	Modell Type Modelo Modelo	Menge Quantity Nombres Cantidad	Tragegestell	Carrying frame	Cadre porteur	Deposito
1	00 44 144		6	Nieten 5,7x18 mm	Rivet	Rivet	Remache
2	00 98 101		1	Rückenkissen	Back cushion	Coussin dorsal	Almohadilla
3	00 61 361		6	Filz 15x55x1,5 mm	Felt	Feutre	Fieltro
4	40 73 122		1	Rückenplatte	Back plate	Plaque dorsale	Chapa
5	40 74 275		2	Gurtbefestigung	Strap holder	Fixation de bretelle	Fijacion
6	40 74 126		2	Kappe	Cap	Capuchon	Caperuza
7	00 18 363		2	Linsenschraube 5x20 mm	Screw	Vis	Tornillo
8	40 35 120		1	Rohrbügel links	Frame left	Tube coudé gauche	Estribo
9	40 35 119		1	Rohrbügel rechts	Frame right	Tube coudé droite	Estribo
10	00 18 275		2	Linsenschraube 5x30mm	Screw	Vis	Tornillo
11	40 46 100		4	Spannbügel	Frame	Etrier de tension	Estribo
12	00 18 274		4	Linsenschraube 5x16 mm	Screw	Vis	Tornillo
13	40 73 125		1	Stützstrebe	Support bracket	Antibalancant	Tirante
14	00 18 340		2	Zylinderschraube M5x40 mm	F.H. screw	Vis	Tornillo
15	40 73 126		1	Klemmbrücke	Clamp	Collier	Abrazadera
16	00 18 370		3	Linsenschraube 6x20 mm	Screw	Vis	Tornillo
17	00 18 363		4	Linsenschraube 5x20 mm	Screw	Vis	Tornillo
18	60 43 107		3	Flanschblech	Flange plate	Tôle de bride	Chapa
19	00 73 396		3	Dämpfungsfeder 3x19x26 mm	AV spring	Ressort amortisseur	Resorte AV
20	40 73 123		1	Bodenplatte	Base plate	Plaque de base	Chapa
21	00 28 137		2	Sechskantmutter M5	Hex. nut	Ecrou	Tuerca
22	00 18 274		3	Linsenschraube 5x16 mm	Screw	Vis	Tornillo
23	00 18 370		4	Linsenschraube 6x20 mm	Screw	Vis	Tornillo

Motor- Druckspritze 432

solo®

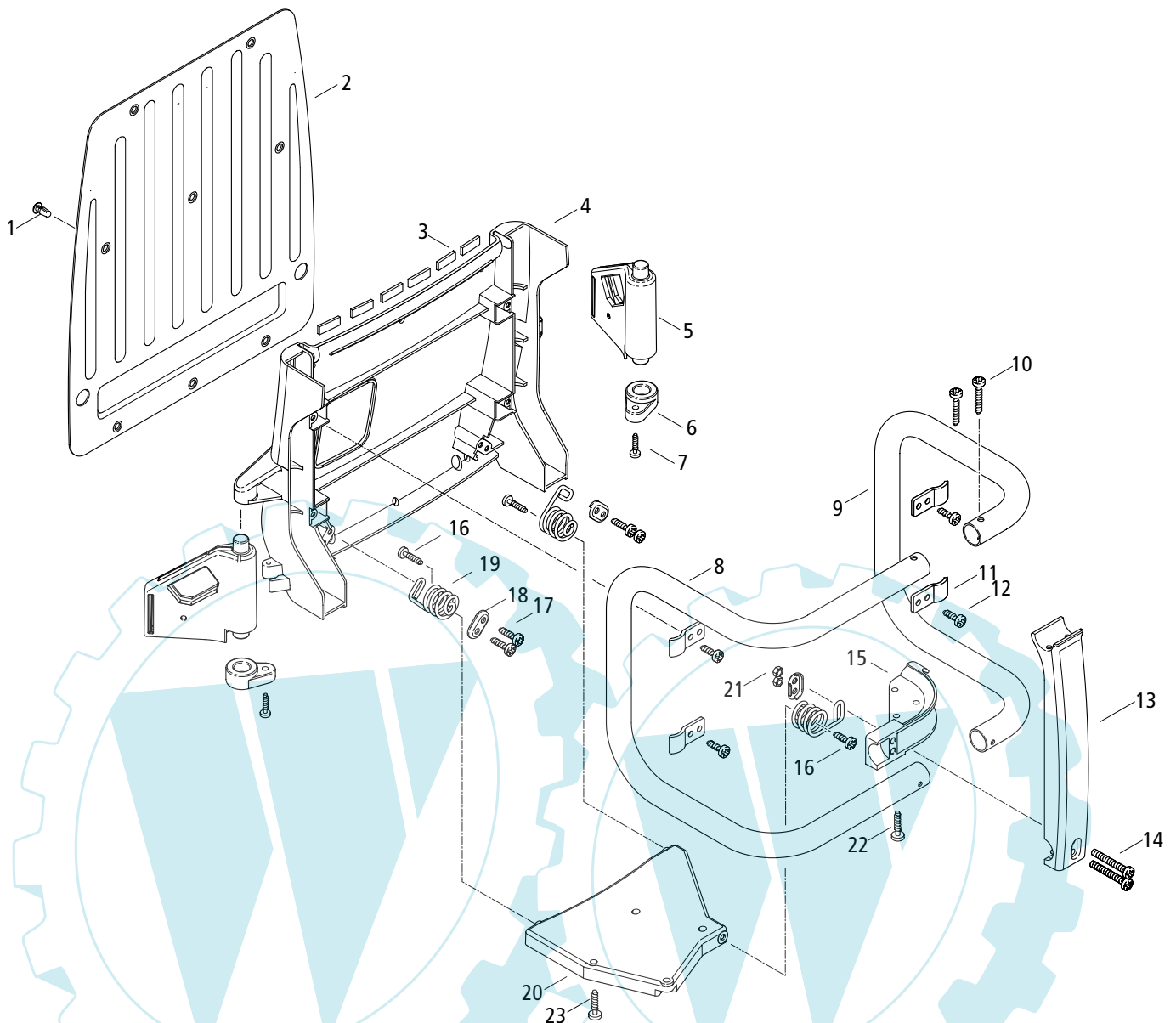

Bild-Nr. Pos.-No. Pos.-No.	Bestell-Nr. Order-No. No. de Cde. Ref.-Nr.	Modell Type Modélo Modelo	Menge Quantity Nombres Cantidad	Behälter, Tragegurt	Tank, Carrying strap	Réservoir	Deposito
1	43 00 332		2	Tragegurt	Carrying strap	Bretelle	Cinturon portador
2	40 74 412		2	Gurthalter	Strap holder	Port-bretelle	Fijacion
3	42 00 327		1	Behälter 20l komplett enth. (-> 3-11)	Tank 20l cpl. incl. (-> 3-11)	Réservoir 20L cpl. y inclus: (-> 3-11)	Deposito 20l incl. (-> 3-11)
4	42 00 142		1	Behälter 20 l	Tank 20l	Réservoir 20L	Deposito 20l
5	42 00 104		2	Einfüllkorb mit Sieb	Filler basket	Entonnoire	Cesta
8	42 00 337		1	Deckel komplett enth. (-> 8-11)	Cover cpl. incl. (-> 8-11)	Couvercle cpl. y inclus: (-> 8-11)	Tapa incl. (-> 8-11)
9	00 62 331		1	O-Ring 124x4,5 mm	O-ring	Joint torique	Anillo
10	40 74 123 25		1	Belüftungsdeckel	Cover	Couvercle d'aération	Tapa
11	40 61 464		1	Ventilplatte (->))	Valve plate (->))	Joint de soupape (->))	Chapa (->))
12	40 73 121		1	Spritzrohrhalterung	Tube support	Support de tube	Soporte
15	00 64 234		190 mm	Schlauch10x3	Hose	Tuyau	Tubo
16	00 64 234		270 mm	Schlauch10x3	Hose	Tuyau	Tubo
17	00 64 234		300 mm	Schlauch10x3	Hose	Tuyau	Tubo
18	00 66 664		6	Schelle12/22x9 mm	Clamp	Collier	Abrazadera

Motor- Druckspritze 432

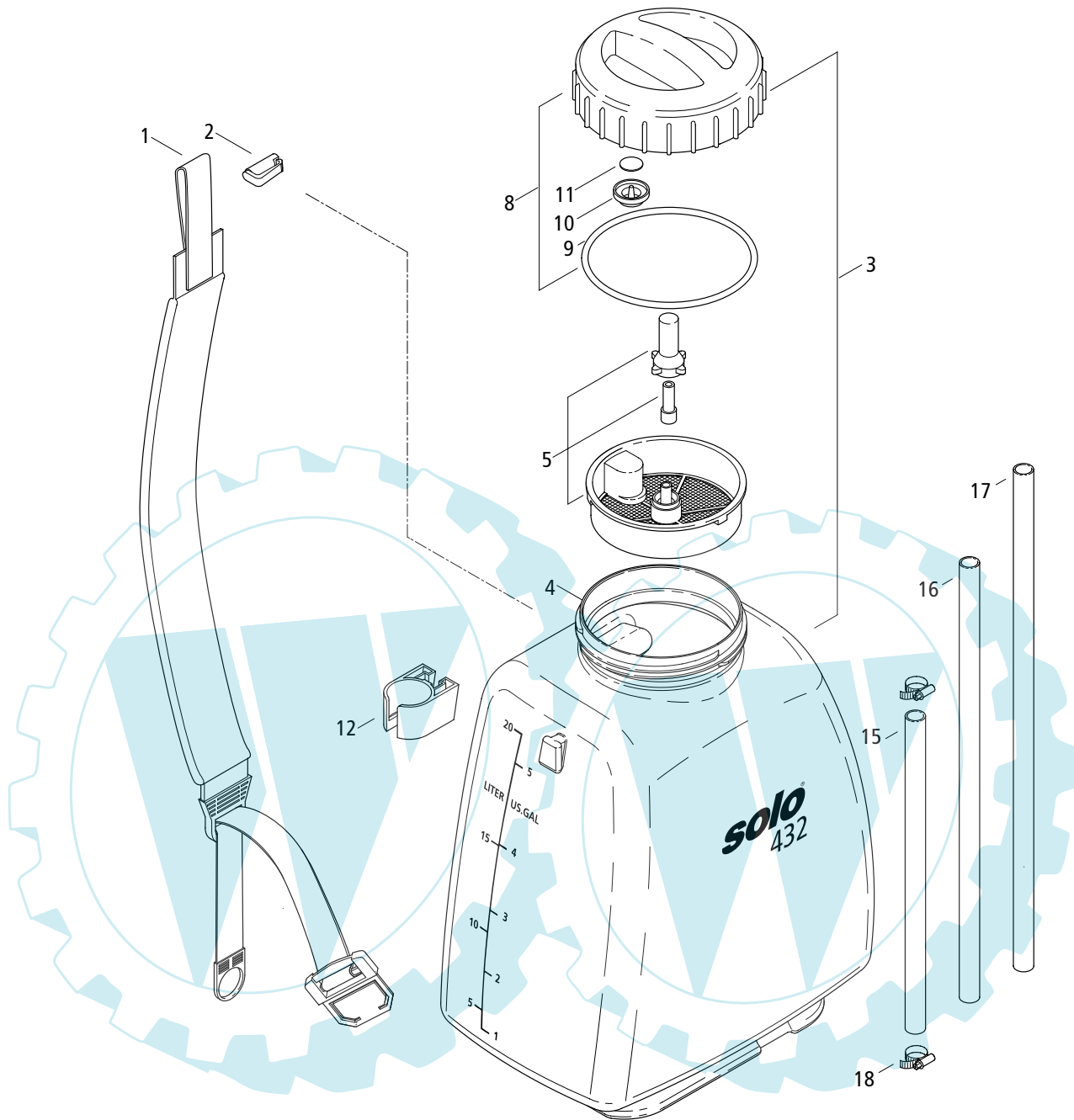

Bild-Nr. Pos.-No. Pos.-No.	Bestell-Nr. Order-No. No. de Cde. Ref.-Nr.	Modell Type Modélo Modelo	Menge Quantity Nombres Cantidad	Spritzrohr	Spray wand	Tube de pulvérisation	Tubo
1	48 00 175		1	Handventil enthält (-> 1-9)	Shut-off valve incl. (-> 1-9)	Robinet d'arrêt y inclus : (-> 1-9)	Empunadura incl.(-> 1-9)
2	40 74 331		1	Hahngehäuse	Housing	Carter robinet	Carter
3	06 10 402		1	Reparaturset Handventil	Repair kit	Jeu de réparation	Juego rep.
4	40 74 338		1	Überwurfmutter R 3/4"	Screw cap	Ecrou de raccord	Tuerca
5	00 62 249		1	O-Ring 5x3 mm	O-ring	Joint torique	Anillo
6	49 00 622		1	Manometer mit Schutz	Pressure gauge	Manomètre	Manometro
7	40 74 335		1	Handhebel	Lever	Levier	Palanca
8	40 74 295		1	Bolzen 4,8x26,5 mm	Bolt	Goujon	Perno
9	40 74 329		1	Haltebügel <-)	Support bracket <-)	Crochet <-)	Estribo <-)
10	00 62 271		1	O-Ring 10x3 mm	O-ring	Joint torique	Anillo
11	40 74 500		1	Klemmstück	Clamping piece	Pièce de serrage	Abrazadera
12	00 31 347		1	Scheibe 17x24x1 mm	Washer	Rondelle	Arandela
13	40 74 987		1	Überwurfmutter R 3/4"	Screw cap	Ecrou de raccord	Tuerca
14	00 64 234		1,2 m	Schlauch 10x3 mm	Hose	Tuyau	Tubo
15	00 66 664		1	Schelle 12/22x9 mm	Clamp	Collier	Abrazadera
18	00 62 258		1	O-Ring 16x3 mm	O-ring	Joint torique	Anillo
19	49 00 421		1	Spritzrohr	Spray tube	Tube de pulvérisation	Tubo
20	40 74 337		1	Überwurfmutter R 3/4"	Screw cap	Ecrou de raccord	Tuerca
21	00 62 115		2	O-Ring 10x2 mm	O-ring	Joint torique	Anillo
22	40 74 527		1	Winkelstück R 3/8"	Elbow	Coude	Codo
23	40 74 922		1	Filtereinsatz	Filter insert	Élément filtre	Filtro
24	49 00 206		1	Hochstrahldüse enthält (-> 24-26)	Adj. nozzle incl. (-> 24-26)	Gicleur à jet élevé inclus: (-> 24-26)	Tobera incl. (-> 24-26)
25	00 62 106		1	O-Ring 12x2 mm	O-ring	Joint torique	Anillo
26	40 74 148		1	Überwurfmutter R 3/8" <-)	Screw cap <-)	Ecrou de raccord <-)	Tuerca <-)

Motor- Druckspritze 432

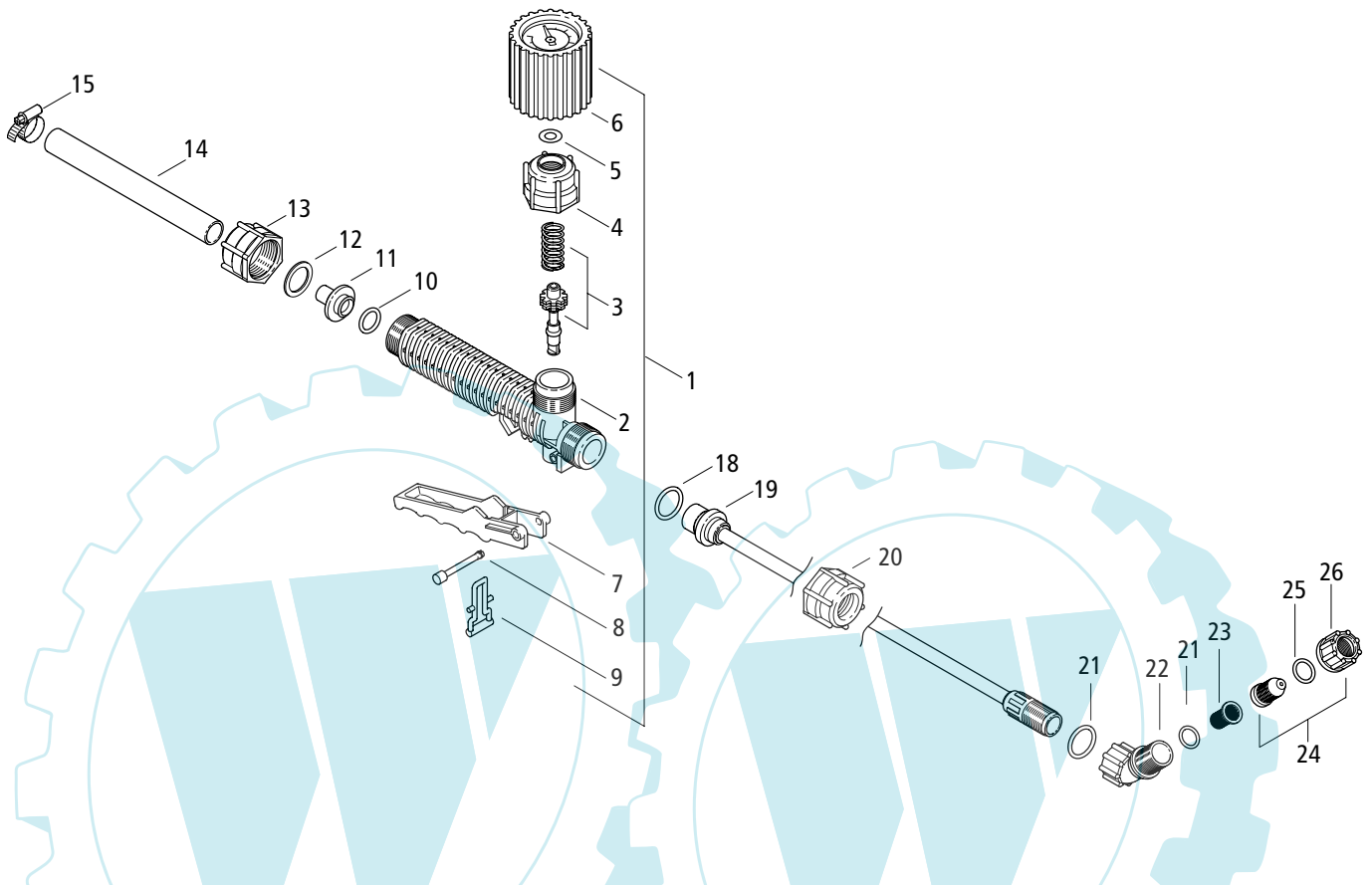

Bild-Nr. Pos.-No. Pos.-No.	Bestell-Nr. Order-No. No. de Cde. Ref.-Nr.	Modell Type Modélo Modelo	Menge Quantity Nombres Cantidad	Ventil	Valve	Soupape	Valvula
1	48 00 226		1	Druckregelventil mit Klemmbrücke enth. (-> 1-22)	Valve incl. (-> 1-22)	Soupape contrôle pression y inclus: (-> 1-22)	Valvula incl. (-> 1-22)
2	00 55 134		1	Sicherungsring 12x1 mm 471	Safety ring	Bague de fixation	Anillo
3	8 00 470		1	Verstellknopf	Adjustment knob	Bouton de réglage	Boton
4	8 50 470		1	Sicherungsring	Safety ring	Bague de fixation	Bague de fixation
5	4 80 440		3	O-Ring 17,3x2,62 mm	O-ring	Joint torique	Anillo
6	8 00 460		1	Federführung oben	Spring guide	Guide de ressort sup.	Guía resorte
7	8 00 452		1	Feder	Spring	Ressort	Resorte
8	8 00 440		1	Federführung unten	Spring guide	Guide de ressort inf.	Guía resorte
9	8 01 870		1	Ventilsitz	Valve seat	Siège de soupape	Asiento
10	8 02 200		1	Ventilkörper	Valve body	Corps de soupape	Cuerpo
11	7 40 290		1	O-Ring 14x1,7 mm	O-ring	Joint torique	Anillo
12	24 80 360		1	Stutzen Rücklauf	Socket	Manchon	Munon
13	8 00 680		1	Überwurfmutter	Screw cap	Ecrou de raccord	Tuerca
14	40 43 132		1	Halteblech	Support plate	Plaque de support	Chapa soporte
15	40 74 148		1	Überwurfmutter R 3/8"	Nut	Ecrou	Tuerca
16	40 74 147		1	Stutzen 10x20 mm	Socket	Manchon	Munon
17	00 62 271		1	O-Ring 10x3 mm	O-ring	Joint torique	Anillo
18	8 01 880		1	Stopfen	Plug	Bouchon	Tapon
19	24 80 390		2	Bolzen	Bolt	Goujon	Perno
20	8 00 540		1	Stopfen	Plug	Bouchon	Tapon
21	8 00 520		1	Überwurfmutter	Screw cap	Ecrou raccord	Tuerca
22	24 80 370		1	Ansaugschlauch 432 <-)	Suction hose <-)	Tuyau d'aspiration <-)	Tubo <-)
23	40 73 126		1	Klemmbrücke	Clamp	Collier	Abrazadera
24	00 18 274		3	Linsenschraube 5x16 mm	Screw	Vis	Tornillo

Motor- Druckspritze 432

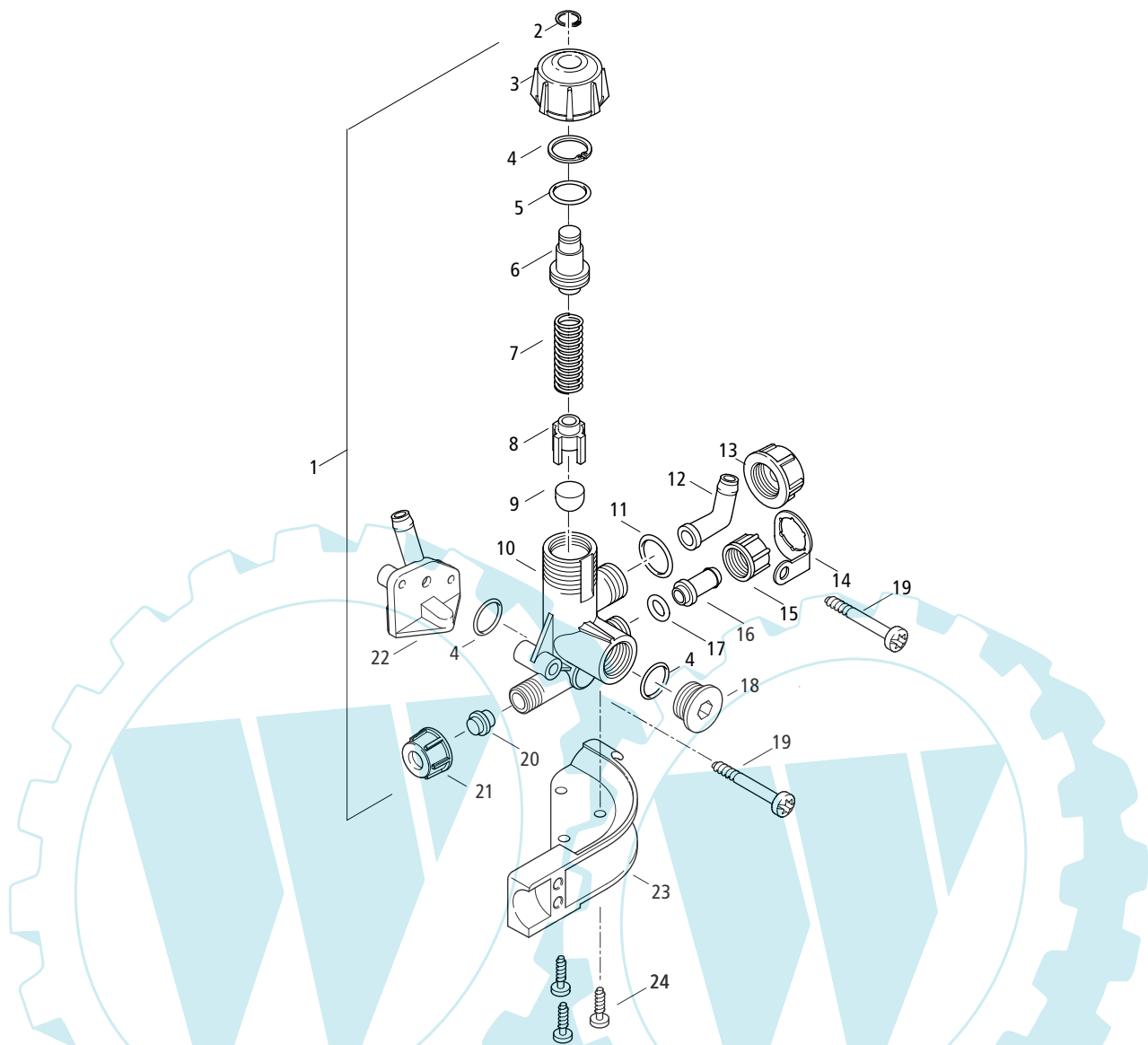

Bild-Nr. Pos.-No. Pos.-No.	Bestell-Nr. Order-No. No. de Cde. Ref.-Nr.	Modell Type Modélo Modelo	Menge Quantity Nombres Cantidad	Pumpe	Pump	Pompe	Bomba
1	44 00 302		1	Hochdruck-Pumpe enthält (-> 1-23	High-pressure pump incl. (-> 1-23	Pompe à haute pression y inclus: (-> 1-23	Bomba incl. (-> 1-23
2	24 80 310		3	Schraube M5x55 mm	Screw	Vis	Tornillo
3	00 30 108		3	Scheibe 5,3 mm	Washer	Rondelle	Arandela
4	24 80 240		1	Pumpenkopf	Pump head	Tête de pompe	Cabeza
5	8 20 490		1	O-Ring 34,65x1,78 mm	O-ring	Joint torique	Anillo
6	24 80 070		1	Ventilbefestigung	Valve lock	Fermeture de soupape	Cierre
7	24 80 040		3	Auslassventil	Outlet valve	Soupape d'émission	Valvula
8	24 80 010		1	Ventilkopf	Valve head	Tête de soupape	Cabeza
9	24 80 030		3	Einlassventil	Inlet valve	Soupape d'admission	Valvula
10	24 80 060		3	Haltestift	Valve lock	Fermeture de soupape	Cierre
11	24 80 330		3	Schraube M4x20 mm	Screw	Vis	Tornillo
12	24 80 090		3	Membran-Befestigungsscheibe	Diaphragm bolt	Goujon de membrane	Perno membrana
13	24 80 020		1	Membrane	Diaphragm	Membrane	Membrana
14	24 80 050		1	Zwischenstück	Plate	Plaque	Chapa
15	24 80 080		1	Taumelplatte	Plate	Plaque	Chapa
16	12 60 770		1	Sicherungsscheibe	Safety ring	Bague de fixation	Anillo
17	24 80 100		1	Pumpengehäuse	Pump housing	Carter de pompe	Carter de bomba
18	24 80 350		1	Verschlusschraube	Plug	Bouchon	Tapon
19	24 80 320		3	Mutter M5	Nut	Ecrou	Tuerca
20	24 80 250		1	Zahnradmitnehmer	Support	Support	Soporte
21	24 80 120		3	Planetenzahnrad	Planetary gear	Engrenage planétaire	Engranaje
22	24 80 340		3	Sicherungsscheibe 7 mm	Safety ring	Bague de fixation	Anillo
23	00 62 339		1	O-Ring 85, 34x1,78 mm <-)	O-ring <-)	Joint torique <-)	Anillo <-)
24	00 72 143		4	Sicherungsscheibe	Safety washer	Rondelle	Arandela
25	00 18 370		4	Linsenschraube 6x20 mm	Screw	Vis	Tornillo
---	00 83 183		72 cm ³	Öl	Oil	Huile	Aceite

Motor- Druckspritze 432

SOLO®

Bestell-Nr. Order-No. No. de Cde. Ref.-Nr.	Menge Quantity Nombres Cantida	Seite Page Page Pagina	Bestell-Nr. Order-No. No. de Cde. Ref.-Nr.	Menge Quantity Nombres Cantida	Seite Page Page Pagina	Bestell-Nr. Order-No. No. de Cde. Ref.-Nr.	Menge Quantity Nombres Cantida	Seite Page Page Pagina	Bestell-Nr. Order-No. No. de Cde. Ref.-Nr.	Menge Quantity Nombres Cantida	Seite Page Page Pagina
12 588	1	3	00 34 152	1	6	20 11 819	1	2; 3	28 00 575	1	4
0 01 873	2	3	00 44 144	6	7	20 31 965	1	6	30 38 206	1	2
4 80 440	3	10	00 44 285	4	5	20 48 377	1	2	40 35 119	1	7
7 40 290	1	10	00 52 141	1	2	20 61 142	1	3	40 35 120	1	7
8 00 440	1	10	00 54 258	2	2	20 61 197	1	3	40 43 132	1	10
8 00 452	1	10	00 54 276	1	2	20 61 464	1	3	40 46 100	4	7
8 00 460	1	10	00 55 134	1	10	20 61 518	1	3	40 61 464	1	8
8 00 470	1	10	00 55 278	2	2	20 63 372	2	2	40 63 253	1	5
8 00 520	1	10	00 61 330	1	5	20 74 111	1	3	40 73 121	1	8
8 00 540	1	10	00 61 361	6	7	20 74 343	1	6	40 73 122	1	7
8 00 680	1	10	00 62 106	1	9	20 74 562	1	2	40 73 123	1	7
8 01 870	1	10	00 62 115	2	9	20 74 570	1	6	40 73 125	1	7
8 01 880	1	10	00 62 249	1	9	20 74 905	1	3; 4	40 73 126	1	7
8 02 200	1	10	00 62 258	1	9	20 74 915	1	6	40 73 127	1	2
8 20 490	1	11	00 62 271	1	9	20 74 977	1	6	40 73 128	1	6
8 50 470	1	10	00 62 271	1	10	21 00 122	1	2	40 73 129	1	5
00 10 519	1	6	00 62 331	1	8	21 00 126	1	6	40 73 131	1	6
00 10 596	1	4	00 62 335	2	2	22 00 133	1	2	40 73 623	1	4
00 13 229	2	3	00 62 339	1	11	22 00 490	1	2	40 73 624	1	4
00 15 299	2	4	00 64 234	190 mm	8	23 00 481	1	4	40 74 126	2	7
00 18 274	2	2	00 64 234	270 mm	8	23 00 730	1	4	40 74 147	1	10
00 18 274	4	7	00 64 234	300 mm	8	23 00 825	1	3	40 74 148	1	9
00 18 274	3	7	00 64 234	1,2 m	9	24 00 125	1	2	40 74 148	1	10
00 18 275	2	7	00 64 419	1	5	24 80 010	1	11	40 74 275	2	7
00 18 282	1	4	00 64 419	1	5	24 80 020	1	11	40 74 295	1	9
00 18 326	1	2	00 66 455	1	4	24 80 030	3	11	40 74 329	1	9
00 18 340	2	7	00 66 664	6	8	24 80 040	3	11	40 74 331	1	9
00 18 354	4	6	00 66 664	1	9	24 80 050	1	11	40 74 335	1	9
00 18 363	4	5	00 69 890	1	6	24 80 060	3	11	40 74 337	1	9
00 18 363	6	6	00 72 140	4	2	24 80 070	1	11	40 74 338	1	9
00 18 363	2	7	00 72 140	2	3	24 80 080	1	11	40 74 412	2	8
00 18 363	4	7	00 72 143	4	11	24 80 090	3	11	40 74 500	1	9
00 18 365	2	3	00 72 144	2	3	24 80 100	1	11	40 74 527	1	9
00 18 370	4	2; 7	00 72 144	2	3	24 80 120	3	11	40 74 800	1	4
00 18 370	3	7	00 72 144	1	4	24 80 240	1	11	40 74 922	1	9
00 18 370	4	11	00 72 148	2	4	24 80 250	1	11	40 74 987	1	9
00 18 399	4	2	00 72 165	1	4	24 80 310	3	11	42 00 104	2	8
00 18 428	2	3	00 72 176	1	2	24 80 320	3	11	42 00 142	1	8
00 20 102	1	2	00 73 360	1	4	24 80 330	3	11	42 00 327	1	8
00 20 106	1	4	00 73 365	1	6	24 80 340	3	11	42 00 334	1	8
00 20 206	1	2	00 73 396	3	7	24 80 350	1	11	43 00 332	2	8
00 28 118	2	4	00 75 100	1	2	24 80 360	1	10	44 00 302	1	11
00 28 137	2	3	00 83 183	72 cm ³	11	24 80 370	1	10	48 00 175	1	9
00 28 137	2	7	00 84 477	1	4	24 80 390	2	10	48 00 226	1	10
00 30 102	4	5	00 84 621	1	4	25 00 104	1	3	49 00 206	1	9
00 30 108	3	11	00 84 869	1	4	25 00 651	1	3	49 00 356	1	9
00 30 135	1	4	00 94 197	4	5	25 00 810	1	3	49 00 421	1	9
00 31 258	2	2	00 98 101	1	7	26 00 140	1	6	60 43 107	3	7
00 31 347	1	9	05 10 984	1	3	26 00 284	1	6	00 63 19 525	1	6
00 31 611	1	6	05 10 985	1	3	27 00 104	1	5	00 64 41 527	380 mm	4
00 33 401	2	4	06 10 402	1	9	27 00 187	1	5	20 31 90 225	1	2
00 34 126	1	6	12 60 770	1	11	27 00 405	1	5	21 00 12 125	2	2
00 34 152	1	6	20 00 628	1	2	27 00 416	1	5	40 74 12 325	1	8

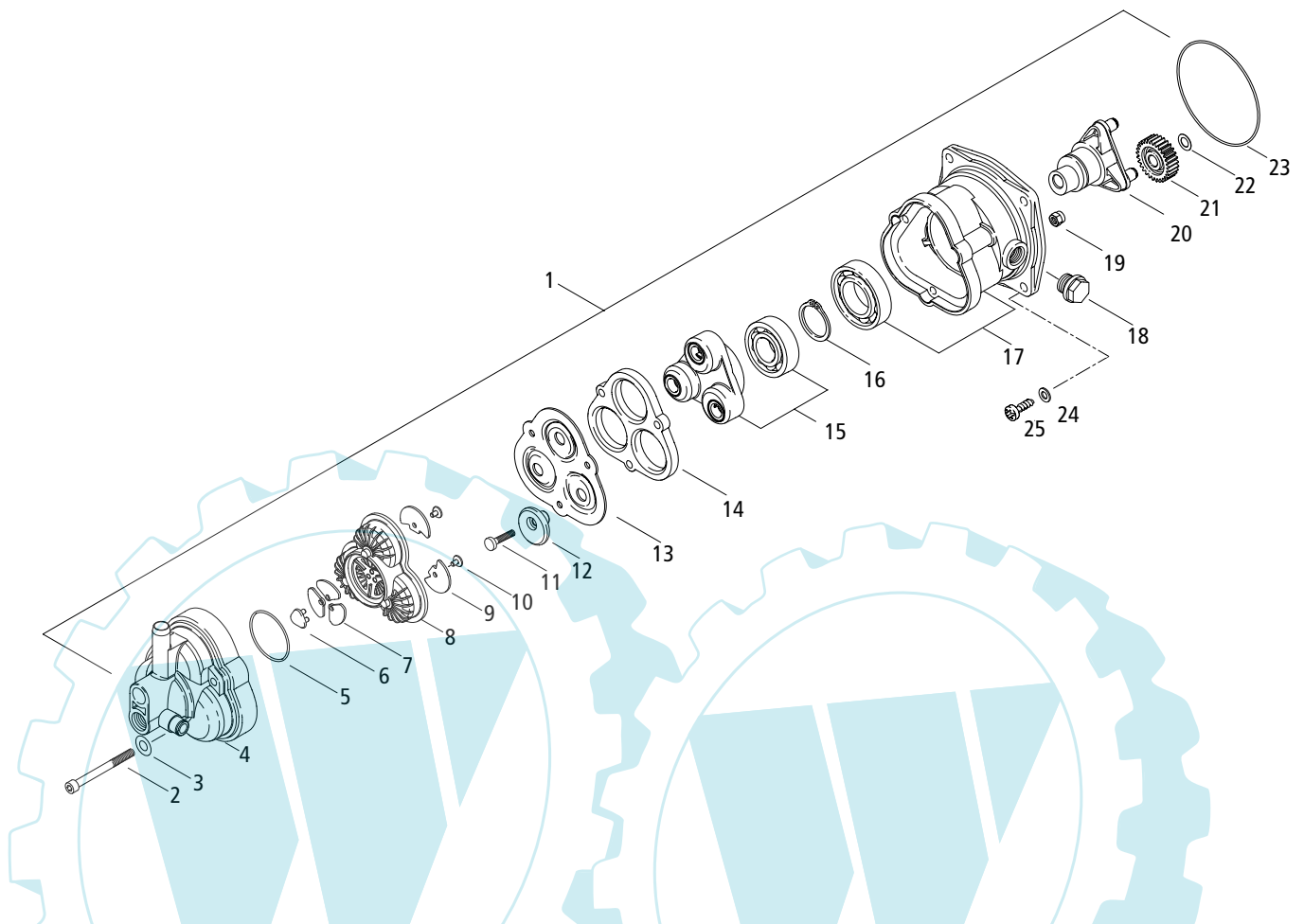
(D)

Allgemeine Richtlinien für die Bestellung von Original SOLO Ersatzteilen:

Voraussetzung für eine reibungslose Erledigung sind folgende Angaben:

1. Ersatzteil-Bestellnummer
2. Gewünschte Anzahl
3. Typenbezeichnung des Geräts

Diese Ersatzteilliste ist für die Lieferung und Ausstattung von SOLO Erzeugnissen verbindlich.

Im Interesse der technischen Weiterentwicklung bleiben Konstruktionsänderungen vorbehalten.

(GB)

General Directions for Ordering Original SOLO Spare Parts:

For correct and diligent processing of your order, please give the following information:

1. Spare Part number
2. Quantity
3. Model and serial number
4. Shipping instructions

Delivery is made in accordance with our general sales and delivery conditions. This spare parts list is non-committal for us with regard to delivery and layout of SOLO products. In favour of technical improvements, design modifications are subject to change without notice.

(F)

Directives générales pour les commandes de pièces de rechange d'origine SOLO:

Il est indispensable de préciser dans toutes les commandes de pièces:

1. le numéro de référence de la pièce
2. la quantité
3. le type de la machine
4. le mode d'expédition

Les livraisons sont effectuées dans le cadre de nos conditions générales de vente. Toutes modifications réservées.

(E)

Directivas Generales de pedido de la firma SOLO:

Por adelantado de un arreglo sin dificultades necesitamos siguientes indicaciones:

1. Número de repuesto
2. Numero de cantidad
3. Modelo y número de serial
4. Instrucción de Envío

Esta lista de repuestos no es obligatoria para los envíos y/o forma de equipo de los productos SOLO. En el interés del constante desarrollo debemos reservarnos el derecho de cambios.